

Airpax Thermal Sensor-Switch Series 6024 Sealed Immersion-Type Hybrid

The Airpax 6024 Thermal Sensor-Switch offers the function and reliability of a grounded case snap-action thermostat with the sensing capability of a solid-state thermistor in a single economical package. The switch is available in temperature ranges from 40°C to 130°C, with a variety of terminal and body options.

The 6024 Series is ideal for sensing engine oil/coolant or transmission fluid for overheat conditions. Additionally, it provides a solution for engine applications where mounting holes are limited.



SPECIFICATIONS

THERMOSTAT

- **Contacts:**
Gold-plated crossbar for low level switching
- **Contact Rating for 30,000 Cycles:**
1 Amp at 48VDC or 120VAC (switching)
- **Contact Operation:**
Available in open on rise or close on rise
- **Standard Operating Temperature Range:**
40°C to 130°C, $\pm 5^\circ\text{C}$ (104°F to 266°F, $\pm 8^\circ\text{F}$)
- **Shock:** 75G 6ms duration (sawtooth)
- **Vibration:** .06DA, 10-55Hz, 20G 10-2000Hz
- **Insulation Resistance:**
50 Megohms, minimum at 500VDC
- **Dielectric Strength:** 500VAC, 60Hz, thermostat terminal to case across open contacts
Note: Do not apply dielectric test voltage to the thermistor terminal as permanent damage could occur to the sensor element.

THERMAL SENSOR

- **Solid-state Sensing Element:**
Conventional NTC (Negative Temperature Coefficient) and PTC (Positive Temperature Coefficient) thermistors available. Specific resistance values and tolerances are per customer specifications.
- **Standard Operating Temperature Range:**
-40°C to 120°C (Other ranges available)

AIRPAX®

© Copyright 2000 Airpax · All Rights Reserved · 00099 2/00

SELECTION CODE CHART

A Contact Operation

Choose from codes below for specific contact operation.

CONTACT OPERATION

Code O = Open on Rise

Code C = Close on Rise

B Basic Series Number

Select series code 6024 for all variations.

To establish the physical configuration you require, choose the proper code letter from the following tables: terminal, body and tube selections.

To complete the Airpax part number, please contact Airpax. They will provide a four (4) digit suffix that will incorporate the nominal switch operating temperature and the solid-state thermistor requirements that are needed for your application.

HOW TO USE THIS CHART

Each sensor-switch P/N (Part Number) consists of functional “building blocks” to enable the user to specify clearly and precisely the desired characteristics in each selection category. Select the proper Code in each category, then transfer it to “Your PN” boxes above. The last four digits of the part number will be a unique four digit number assigned by Airpax.

The example shown above records a selection of a standard item with a typical code specified in each “building block” category.

EXAMPLE PN:

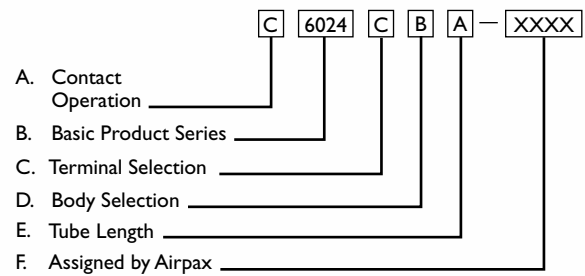

YOUR PN:

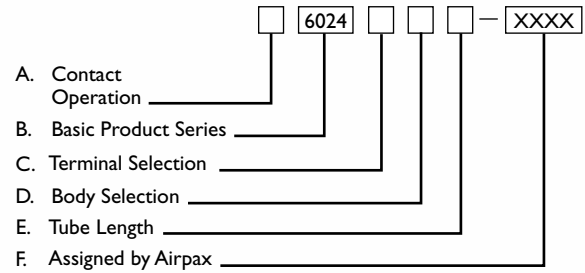

The above example part number describes a device with 6" lead wires, 1/2-14 body and .698" long tube. The thermostat operating temperature and sensor characteristics will be defined by the assigned four digit number.

NOTE: The marking information on each sensor-switch will include the name Airpax, contact operation (CLR for close on rise or OPR for open on rise), top thermostat temperature and date code.



C Terminal Selection

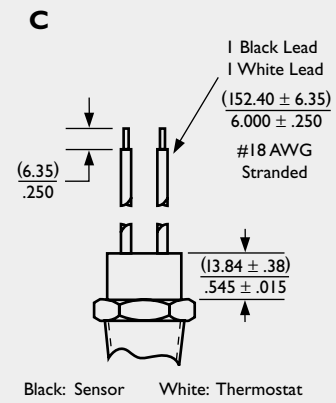
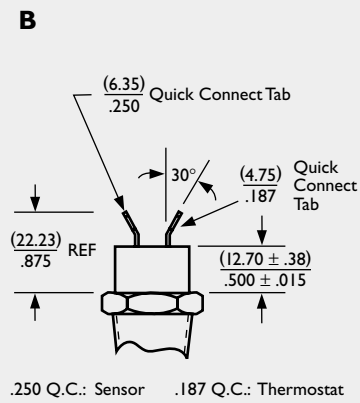
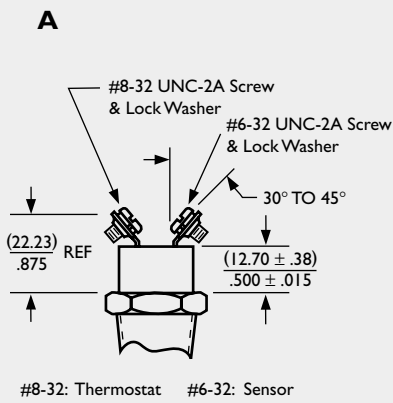

- D** Same as Terminal Selection "C"
Except Lead (304.80 ± 25.40) / 12.00 ± 1.00
#18 AWG Stranded
- E** Same as Terminal Selection "C"
Except Lead (609.60 ± 25.40) / 24.00 ± 1.00
#18 AWG Stranded
- F** Same as Terminal Selection "C"
Except Lead (1219.20 ± 25.40) / 48.00 ± 1.00
#18 AWG Stranded
- Z** Special Requirements
Customer to Specify

D Body Selection

(Note: All sensor tubes attached to end indicated by £)

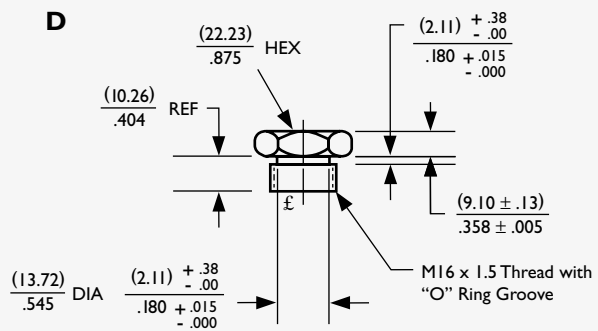
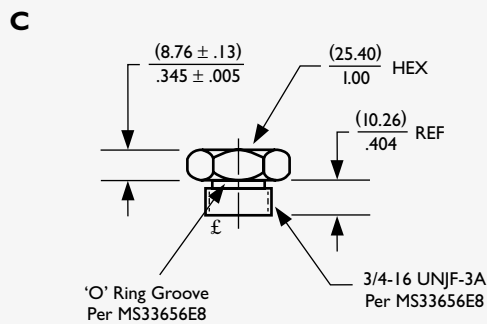
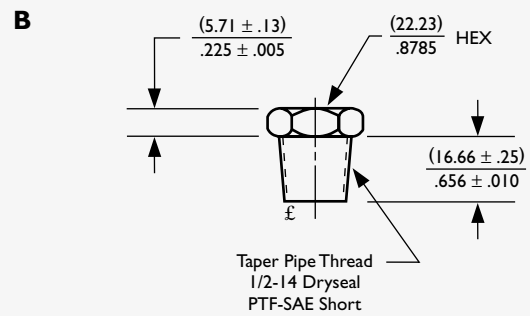
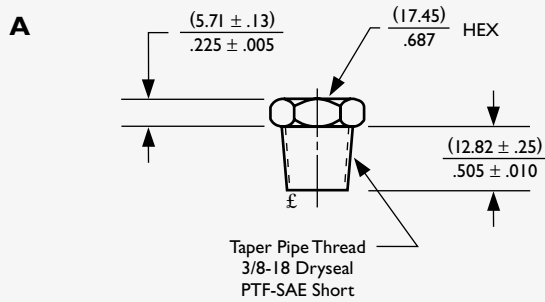

Z
Special Requirements
Customer to Specify

E Tube Lengths

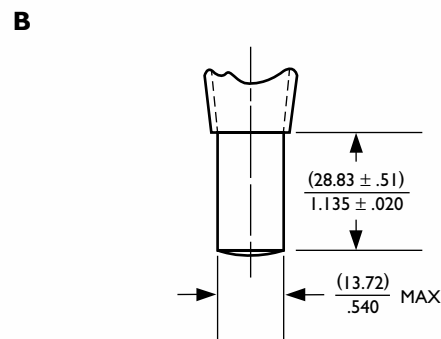
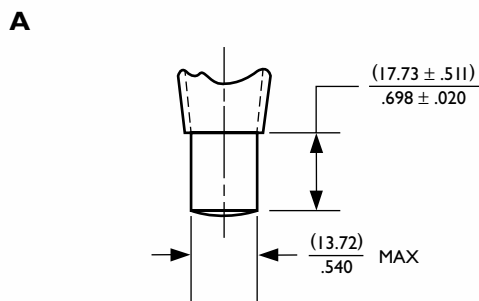

Z
Special Requirements
Customer to Specify



©Copyright 2000 Airpax · All Rights Reserved · 00094 2/00

Airpax Corporation · Thermal Sensing Products
550 Highland Street · Frederick, MD 21701 · USA
TEL: 301.663.5141 · FAX: 301.698.0624 · www.airpax.net